

6/18/2012

**320 Watt M132/M154 60Hz
Pulse Start Metal Halide**

Project:	
Catalog#:	
Approved by:	

Input Volts (60 hz)	120	208	240	277
Input Watts	364	364	364	364
Approx Line Current (Amps)*	3.1	1.8	1.6	1.4
Circuit Type	PS-CWA			
ANSI	M132/M154			
Insulation Class	Class H			
Power Factor	> 90%			
Regulation	Line Volts: ±10% Lamp Watts: ±10%			
Min. Ambient Starting Temp.	-20°F/-30°C			
High Potential Test (Volts)	1 Minute: 1650 1 Second: 2000			
Lead Lengths (inches)	12			
UL Temperature Ratings*	1029 C			
Capacitor*	Included in kit			
Starter/Ignitor	ST1001. Included in kit			

* See Ballast Label for exact values and additional information

WIRING DIAGRAM

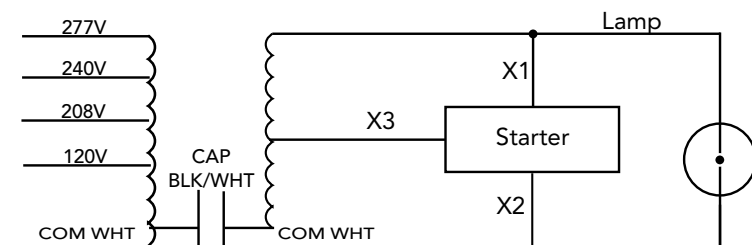

HID Ballast Kit

- Ballast
- Capacitor
- Starter
- Mounting Bracket

DIMENSIONAL DRAWING

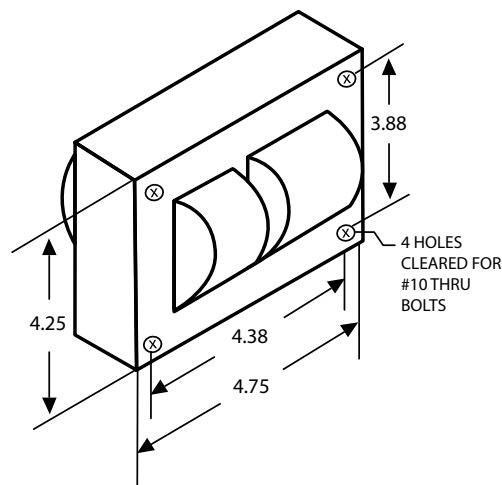

Specifications subject to change without notice.

